



FALCON RIDGE

3510-1 Port Jacksonville Pkwy, Jacksonville, FL 32226
800-213-7981

Instructions for Installation and Care of Kawasaki Teryx 2014-2017 Soft Rear Window KAW-14/16TERYX-RW01

Notice: Do not smoke inside the cab or expose the enclosure to direct flames. Cab is Flammable.

1. Be sure to read these instructions thoroughly before opening and installing the Kawasaki Teryx 2014-2017 Soft Rear Window. The installation is best done when the temperature is 70 degrees F. or warmer. The temperature affects the adhesive Velcro, if conditions prevent installing in warmer weather it helps to store the adhesive Velcro at room temperature prior to installation.
2. Carefully open the carton and remove the enclosure on a large flat surface that is clean and free of dirt.
3. Check over the parts included in the carton with the parts list shown below:

Adhesive Velcro Hook Strips:

| | | | | <u>Rear Window</u> |
|---|---|---|---|--------------------|
| “ | “ | “ | “ | 12 each-----3” |
| “ | “ | “ | “ | 2 each-----4” |
| “ | “ | “ | “ | 2 each-----18” |

REAR WINDOW

1. Begin by placing the 2 4" adhesive Velcro Strips on each side of the Teryx where the side tube meets the top tube. The following photo shows how this should look.



2. Next hang the Rear Window from these adhesive strips making sure to center the window properly. Once this is done attach the two double-sided Velcro strips at the very top corner of the Rear Window. Make sure to pull the top of the Rear Window tight from side to side. At each double-sided Velcro strip you will use one 3" adhesive strip to keep the double-sided strip from moving. The following pictures show how this is done as well as a picture of the Rear Window after it has been attached.

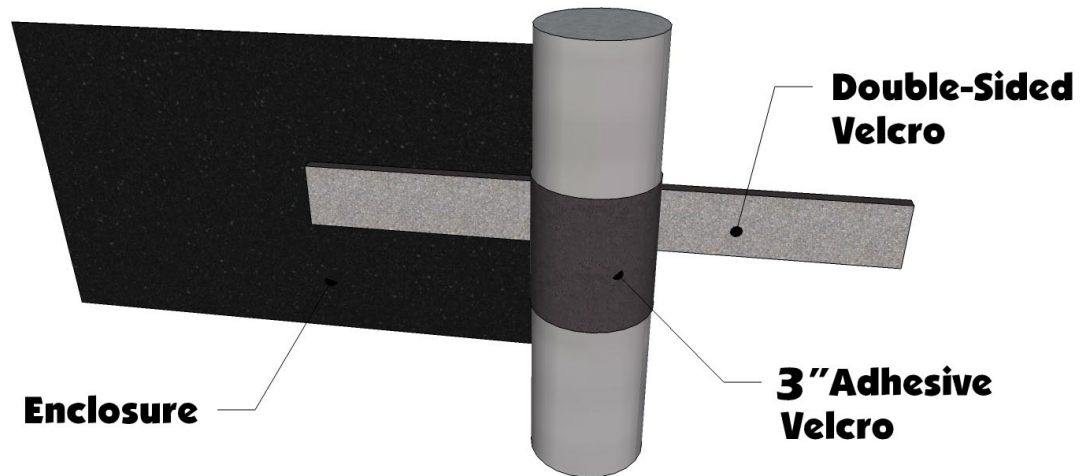
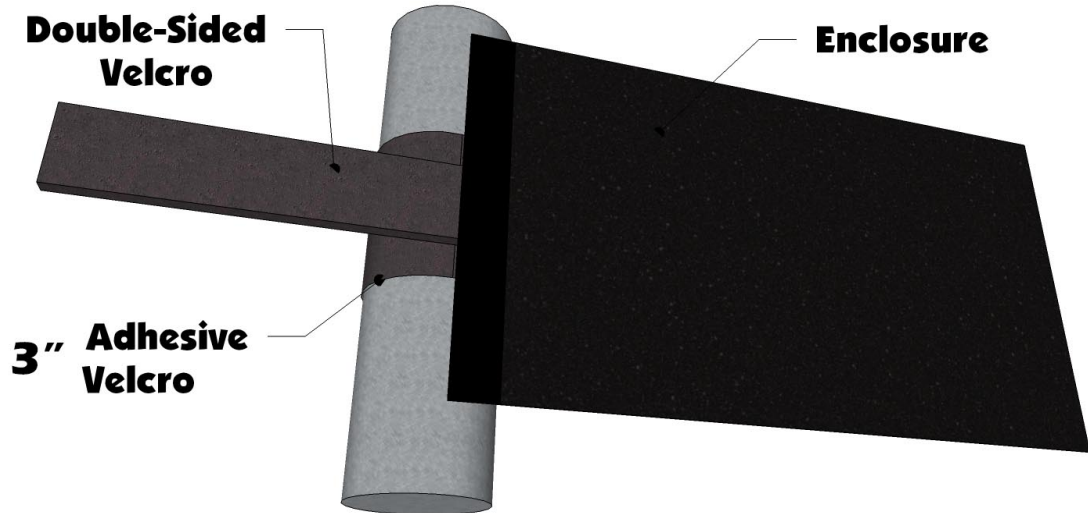

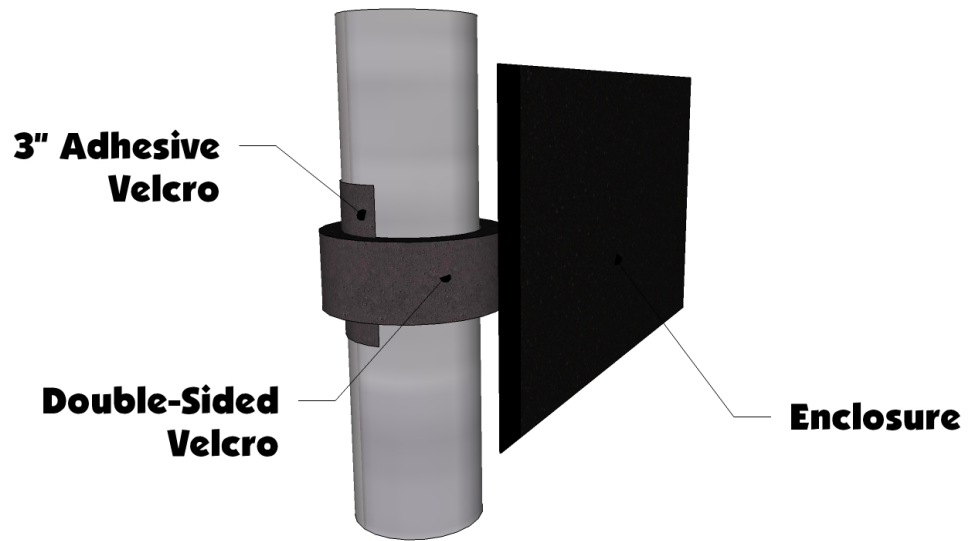

3. Now work your way down each side of the Rear Window attaching the double-sided Velcro strips to the center side bar as shown in the photo below. **NOTE: The Rear window is designed to leave most of the center side bar exposed so the magnets in the doors hold as well as possible so don't pull the sides of the Rear Window too hard.**



4. Last thing to do for the Rear Window is to attach the straps along the bottom to the frame of the seat under the bottom cushion. The following picture shows how it should look.



Cleaning and Storage Recommendations:

1. Before removing the Falcon Ridge Cab for storage, make sure it is very clean in order to prevent scratching of the window panels. Clean with a soft rag or sponge using a mild liquid detergent soap and warm water solution. Never rub the windows with a dry cloth or rag! Let the Cab dry thoroughly before attempting to roll for storage.
2. It is important that the Cab be rolled up for storage rather than folding. Folding will cause damage to the windows!!! Carefully roll up the Cab similar to the way it was when it was packed at the factory. On a large, clean and flat surface, fold the doors over the rear panel first, then, interleave the top and windshield on top of the doors. Begin rolling the Cab into a roll approximately 8 inches in diameter. Put the rolled Cab back into the carton for storage at a normal room temperature. It is best not to expose the Cab to either extreme hot or cold temperatures when storing.
3. A special cleaner conditioner is available from Falcon Ridge that will greatly increase the service life of the Cab Enclosure. In addition, if additional hook and loop sets are needed, they can also be ordered.

Return Policy

If for any reason you choose to return this product it must be returned within **30 days from date item is received**. You **MUST** package the product exactly **as it was originally packaged from the factory to get a full refund for the product!**

The vinyl windows should never be folded when packaging in the box or for storage purposes. Lay all the windows on top of each other with the canvas folded in between and the paper (if available) on both sides of the windows.

All returned products will be inspected upon arrival at the production facility and must be in unused, factory new condition to receive refund - a 25% restocking fee will apply.

If ordered from Falcon Ridge please call at 800-213-7981 to gain a return authorization number, use our preferred shipping carrier (UPS) to return the item (unless the item is defective, you are responsible for paying the shipping to return the item.) **Any returns submitted to Falcon Ridge without a return authorization number will be charged a 20% restocking fee.** If ordered from one of Falcon Ridges many distributors', you must first call them and see what their return policy is. Once your item reaches our production facility, our customer satisfaction team will inspect your item to ensure unused, factory new condition. **NOTE: All windshields must be returned with the original protective film intact and not removed. Do NOT REMOVE if you have any intentions of returning the item. Refund/ replacement of a windshield will only be processed on items with original protective film or if the windshield is defective.**

Items must be properly packaged in the original shipping carton to protect them during transit and ensure your returned item arrives back factory fresh, and in new resalable condition (**any returned items that have been used, altered or damaged in any way will not be subject for a refund.**) All contents including instruction manuals, accessories, hardware, Velcro, etc. must be included in your return shipment. Only items in OEM factory new condition will be approved. Once returned items are received, credit will be issued to the original credit card/ payment method used for the purchase. Outbound shipping and return shipping cost will not be refunded. Please allow 4 to 6 weeks for your refund to be processed.

Warranty

To The Owner of this Product:

Thank you for purchasing one of Falcon Ridge Cab Enclosures, Tops &/or Windshields! Below are the terms under which your product is covered under our manufacturer's warranty.

30 Day Warranty which includes and is not limited to replacing the enclosure, tops and/or windshield due to defect of the product. Please refer to the return policy in this case for more information.

1 Year Warranty includes any defect in material or workmanship within this time frame we will gladly correct the problem or replace the enclosure, tops &/or windshield. Upon submitting for the correction or replacement we will need to receive pictures of the defect in material or workmanship along with the receipt from the date of purchase.